

Worldwide Fuel Cell Activity: UK Perspective

Dr Jon Butler, Dr. Kerry-Ann Adamson & Dr. Ben Todd
Low Carbon and Fuel Cell KTN

Knowledge Supply to a Nascent Fuel Cell Industry
Energy Crossroads, IVA, Stockholm, 11 December 2008

The Low Carbon and Fuel Cell KTN - Background

- Funded by the UK government's Technology Strategy Board
- Operated by Fuel Cell Today, Fuel Cells UK and Foresight Vehicle under the stewardship of CENEX
- **The mission of the Fuel Cell Technology KTN...**

... to provide an accessible and flexible platform for communication and cooperation between members of the UK specialist fuel cell community, as well as non-specialist and non-UK groups which will also play a vital role in bringing products to market.

Low Carbon and Fuel Cell Technology Knowledge Transfer Network

Aimed at accelerating business
innovation in the UK fuel cell
sector

- www.fuelcellktn.com
- Range of services:
 - Project brokering
 - International brokering
 - Real and online events
 - Industry directory
 - Online conferencing
 - Partner search
 - Alerts
 - Viewpoint articles
 - UK news & events

The screenshot shows the homepage of the Fuel Cell Technology Knowledge Transfer Network. At the top, there is a navigation bar with links for Home, Low Carbon, Fuel Cells, About Us, and Login or Register. The main content area is divided into several sections:

- From the Moderator:** A section featuring a photo of Graeme Purdy, dated November 2007.
- View Point:** A section featuring a photo of Graeme Purdy.
- Product Focus:** A section featuring a photo of a fuel cell system, with the text "CFCL - NetGen".
- Company Focus:** A section featuring a photo of a fuel cell system, with the text "Ilika Technologies".
- WELCOME to the Fuel Cell Technology KTN:** A central text block explaining the network's mission and providing contact information for Fuel Cell Today and Synnogy / Fuel Cells UK.
- Join the KTN community!:** A section with a "LOG IN / REGISTER" button and a photo of a group of people in a meeting.
- Where this icon appears:** A section with a small icon and the text "Content is exclusive to Registered Members".
- KTN News:** A section titled "FUEL CELLS AND HYDROGEN: UPDATES FROM THE USA" with a key speaker, date, and time.
- Login/Register:** A section with a "Login/Register" button and a photo of a group of people in a meeting.
- Alerts:** A section with a yellow warning triangle icon.
- What's New:** A section with a "What's New" button and a photo of a group of people in a meeting.
- Contact the KTN:** A section with a "Contact the KTN" button and a photo of a group of people in a meeting.

Fuel Cell Today is the leading organisation for market based intelligence on the fuel cell industry. Covering key trends and developments in industry and government, Fuel Cell Today provides relevant, unbiased and objective information allowing decision makers to take advantage of the opportunities that our new industry offers.



Presentation Outline

Global

1. Key Developments, 2007
2. Stationary
3. Transport
4. Portable
5. Summary

UK

1. UK Funding Structures
2. UK Research
3. UK Companies

When is a Fuel Cell Commercial?

“A fuel cell is considered commercial if it is:

- Offered for sale to the public,
- Offered with a written warranty, supported by service capability,
- Meets approved industry standards or is certified by an established industry body”

Definition adopted from the US Fuel Cell Council

Key Developments, 2007

- Industry growth rate in units shipped 2006 to 2007 75%
- Direct government support topped £100 million in FY07
- Implementation of the ICAO ruling in the US to allow methanol cartridges in aircraft hand luggage
- Japanese government subsidy for residential fuel cells switched from the producer to the consumer
- Some early applications cost competitive with incumbent technologies
- Increased number of ISO, TÜV and UL certified products.



Stationary

Any permanently fixed fuel cell



Stationary Development 2005 – 2007

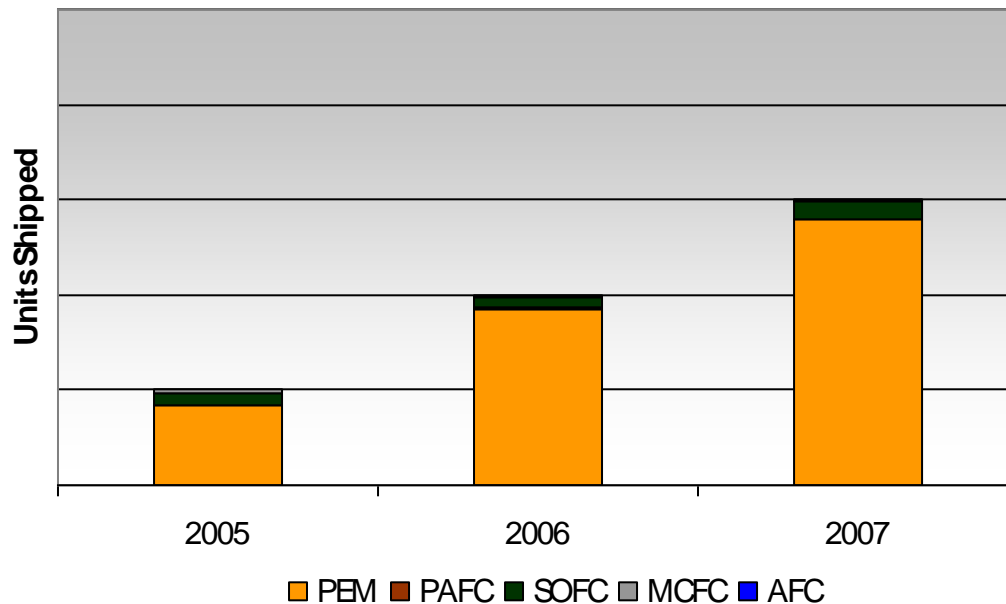

AGR 125%

Key Points:

- Global market, some 30+ countries now with operating stationary fuel cells
- UPS systems increasing rapidly in terms of distribution and sales
- At present commercial companies in NA concentrating on UPS whilst in Japan with focus on residential markets
- In 2007 units under 10 kW (PEM, SOFC and AFC) contributed under 5 MW of power whilst units over 10 kW (MCFC and PAFC) contributed approximately 8 MW

Stationary Funding FY07

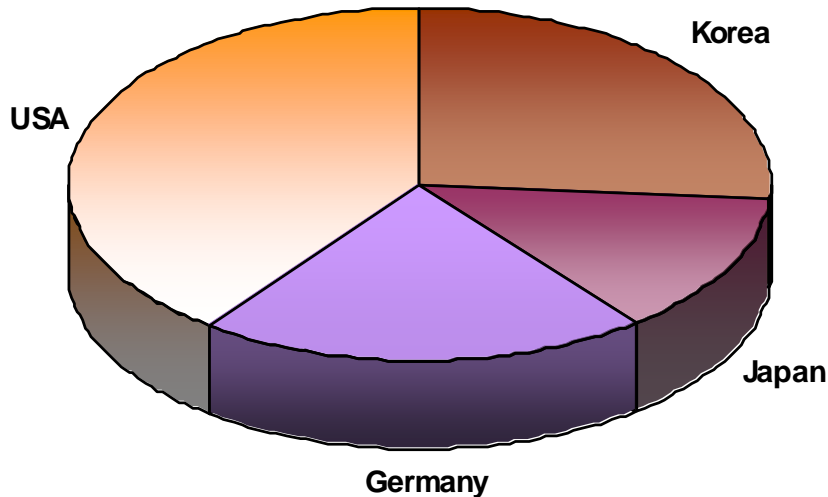

- South Korea - Around £10 million for MCFC power plant development and a further £5 million for residential fuel cells
- Japan - Very clear funding structure with stationary receiving £24 million (£2 million more than transport)
- USA - £30 million available from the SECA programme for SOFC development. Parallel military SOFC programme adds approximately a further £2.5 million to this
- *(Other money is available in countries such as the UK with integrated funding streams)*

Policy and Legislation

Japan

- Large Residential Fuel Cell Programme most proactive in the world
 - Clear long term technical targets outlined in 2005 with subsidies for production available to 2007. Funding switching from producer to consumer in 2008

USA

- Federal level policies aimed at fundamental R&D (primarily transport). Work at State level critical with for example interconnection standards being developed at this level

Europe

- The new Joint Technology Initiative outlines a number of long term goals for stationary fuel cells (Routemap of adoption not yet published)
- Nordic states proactive with development of cross border policy including stationary (and transport fuel cell) adoption

Stationary Outlook - Fuel Cell Units by Shipment and Region

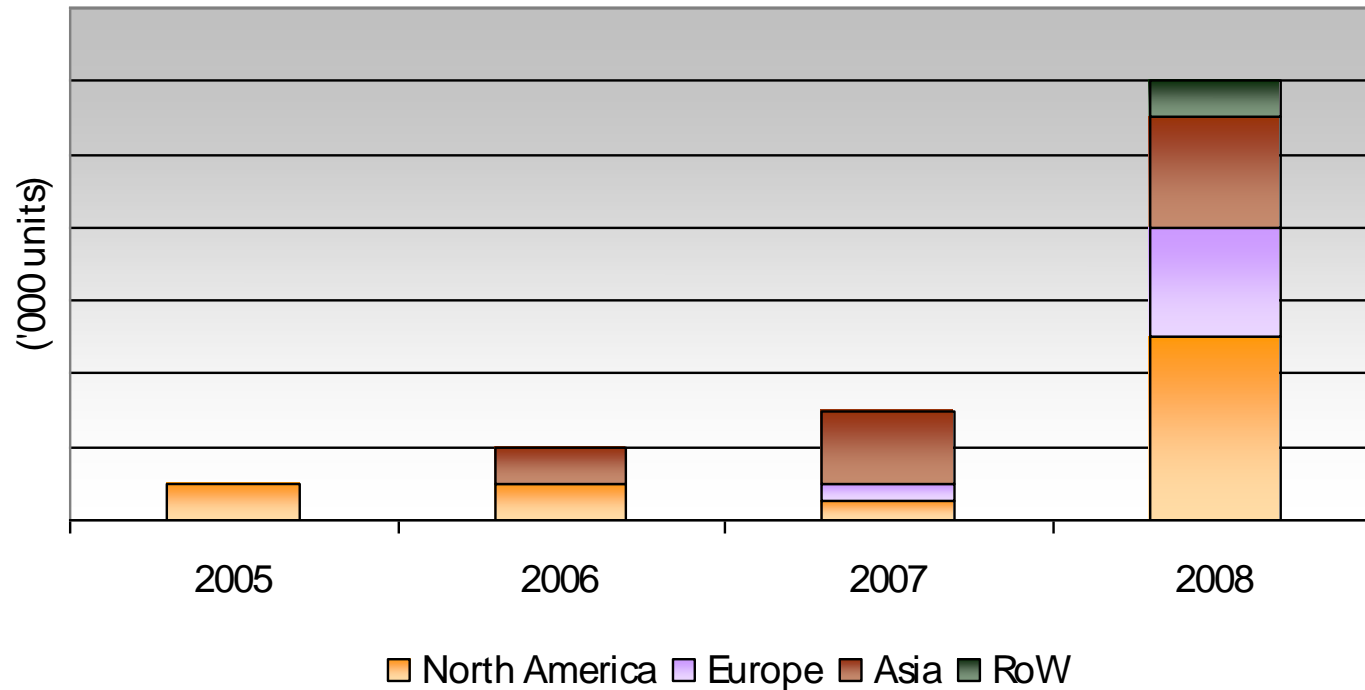

Transport

Any unit that is included in a vehicle whether for direct propulsion or on-board power.



Transport Development 2005 – 2007

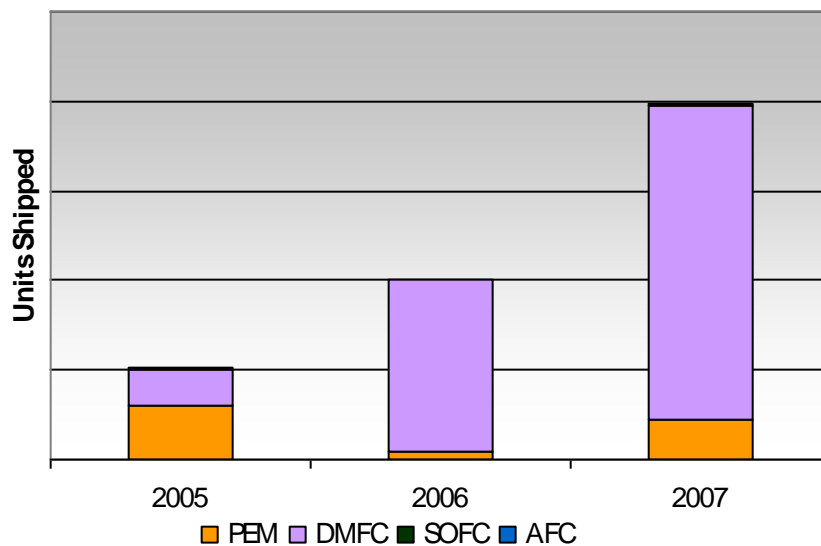

AGR 150%

Key Points:

- Niche markets fastest growing, especially APU deployment in the leisure industry (campervans and boats)
- Very large spread of vehicles being developed with programmes being in the low tens of units
- Number of highly successful and ongoing bus demonstration programmes
- 2007 saw jump in interest in fuel cells for materials handling vehicles

Transport Funding FY07

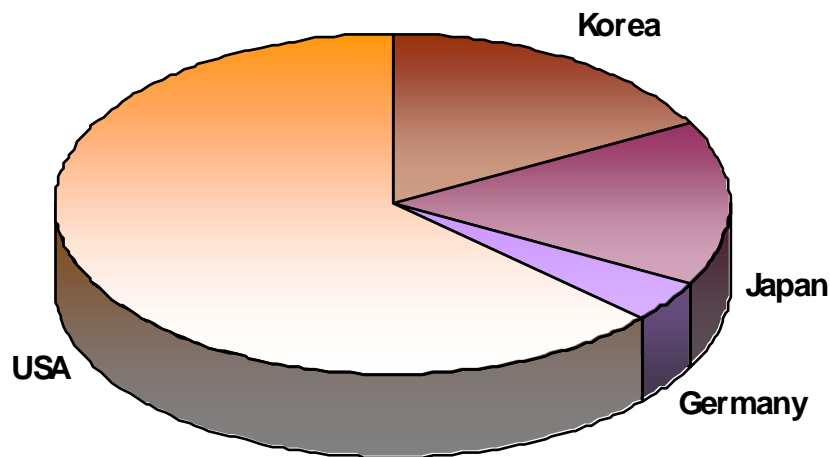

- USA - money channelled through the FreedomCar programme of ~ £88 million (similar level request in FY08) specifically for FCV development
- Japan – money also specifically for FCV development , £22 million FY07
- Germany – using funding for electrolyte types rather than vehicle types, i.e. PEM and DMFC for transport

Policy and Legislation

Policy and legislation driving fuel cells into the market in some regions, e.g. Shanghai with the prohibition of petrol driven motorbikes and the creation of “low emission harbours”

Japan

- Currently a basket of next-generation vehicle fuels being considered, including batteries, biofuels and hydrogen fuel cells
- Soft infrastructure such as codes and standards for transport being developed

USA

- Replacement Fuel Goal and US Energy Act 2007 key policy developments in 2007 at Federal level.
- State level, again, is highly proactive.

Europe

- ‘Type Approval’ system for hydrogen vehicles is under development, in parallel with the JTI

Transport Outlook - Fuel Cell Units by Shipment and Region

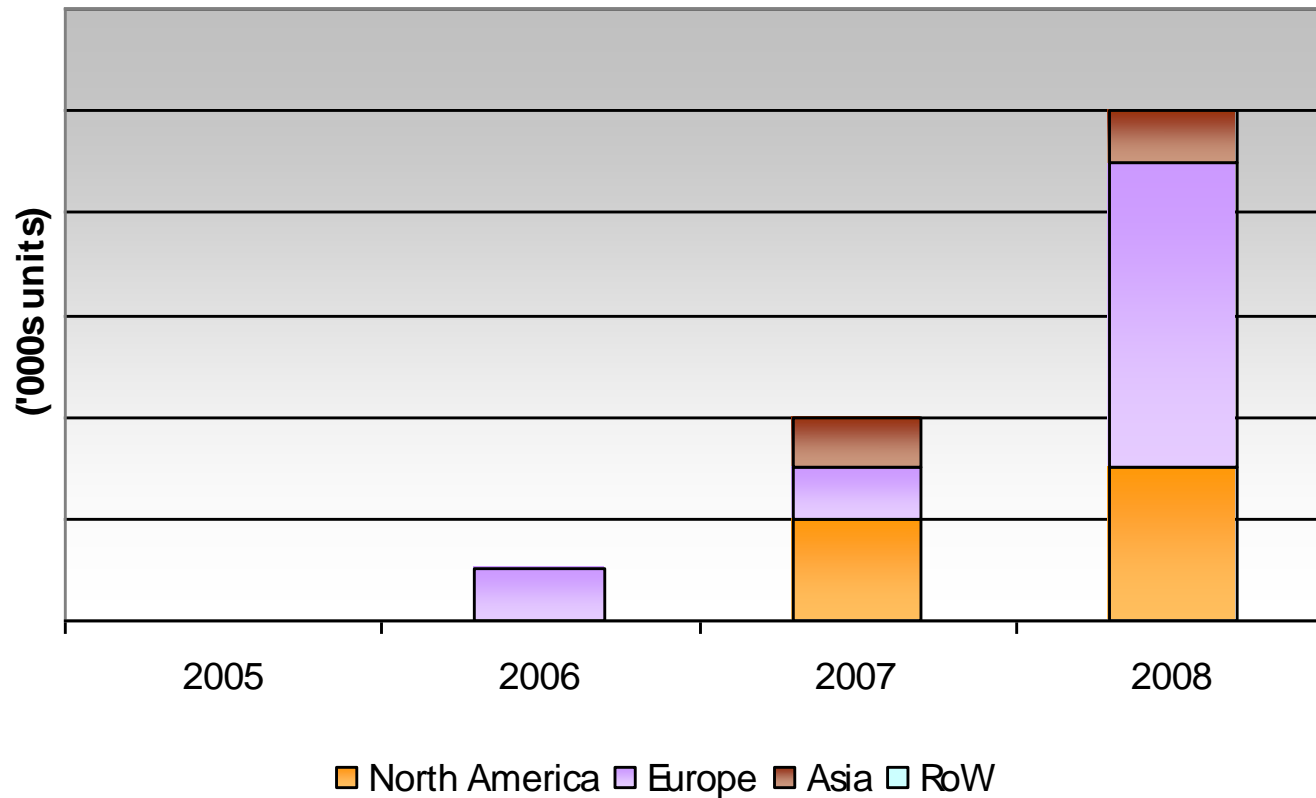

Portable

Any fuel cell that is designed to provide power to portable objects

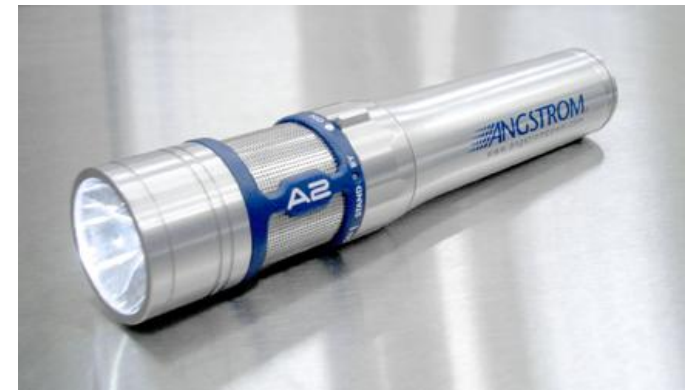

Portable Development 2005 – 2007

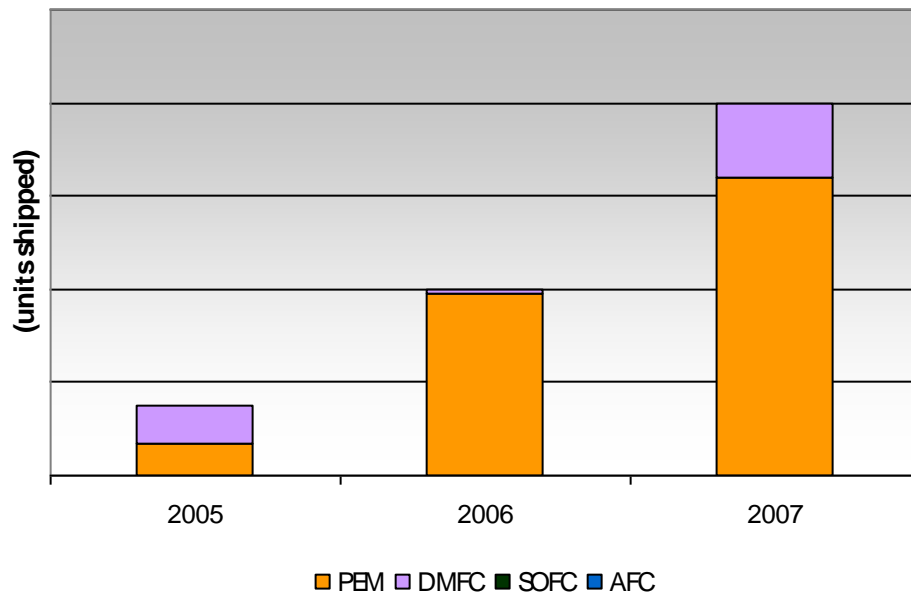

Key Points:

- First market to support volume shipments
- 2005 saw fairly equal split between DMFC and PEM, 2006 flipped to PEM though this dominance started to be challenged in 2007
- Non-military development in Asia by large multinationals whilst conversely in SME development in NA is supported military work

Portable Funding FY07

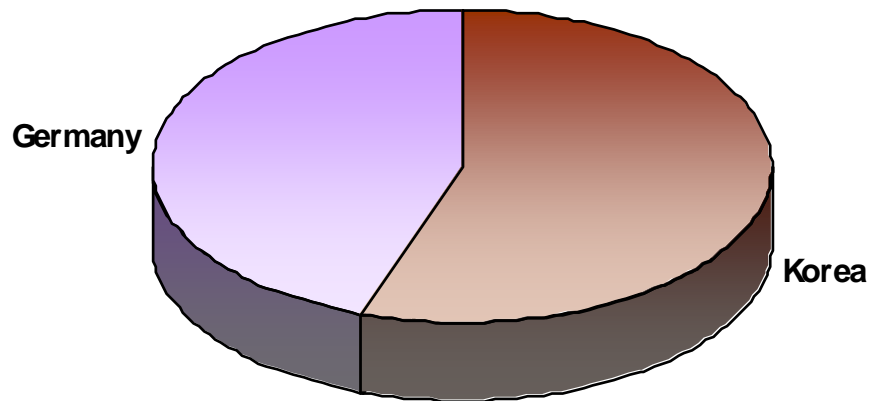

- USA – portable funding comes from the military, not shown in the graph, and adds approximately £11 million to this figure. Over 90% of this funding is for field of combat developments
- S. Korea – is working in collaboration with Samsung on portable developments.
- Germany – some £4 million was available for development of PEM portable systems.

Portable Outlook - Fuel Cell Units by Shipment and Region

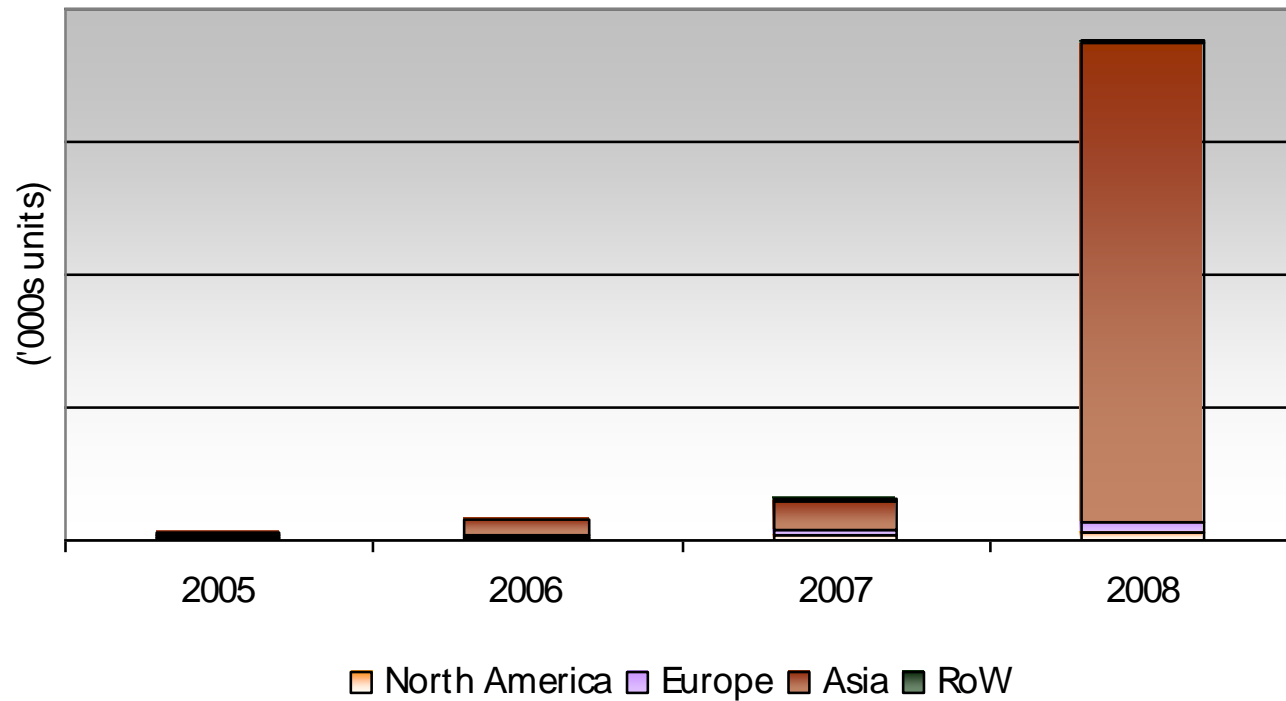

Summary

- We believe that the start of full commercialisation of fuel cell technology started in 2007
- A number of applications are *cost competitive*
- A number of products hold international *certification*
- A growing number of products are available in the open market place

Auxiliary power units, uninterruptible power supply systems, combined heat and power units, power plants, toys, submarines, and materials handling vehicles are all proving that fuel cells are no longer just about hype but are now, increasingly, a market reality.

Fuel Cell Today Industry Review 2009

Fuel Cells: Commercialisation

Launch in January 2009



UK policy landscape

- EU Hydrogen and Fuel Cell Joint Technology Initiative (H2FC JTI)
 - Microgeneration support strategy
 - King Review of Low Carbon Cars
- 
- EUR 1 billion RD&D funding available over next decade
 - Possibility of support for fuel cell mCHP
 - Fuel cell vehicles seen as a longer term (20-30 yr) prospect to meet CO₂ targets

Carbon Trust

Key focus: carbon saving potential

Breadth of low-carbon innovation activities, from R&D to demonstration, VC investment and full commercialisation
Seen as key partner by IP-sensitive innovators, especially universities, spin-outs and SMEs
Track record of delivery for ~5 years
Track record of links from innovation activities to policy making
Independent from Government and industry

TSB

Key focus: economic benefit for UK

Wider coverage than low-carbon/energy and potential to leverage cross-cutting disciplines
Established reputation with business sector
Strong focus on networking (KTNs) and skills transfer (KTPs)
Role in encouraging increased R&D spend in private sector
Independent from Government and industry

ETI

Key focus: route to market

Significant scale of funding available
Potential to fund projects at 100% due to combined public/private funding
Industry backed with direct route to market via industrial members
Access to management and engineering capabilities within industrial members

Selected UK Fuel Cell Research Groups

Birmingham University	Newcastle University
Cranfield University	Nottingham University
Imperial College London	St Andrews University
Keele University	Surrey University
Leeds University	University College London
Loughborough University	Warwick University
Reading University	Southampton University



 The University of Nottingham	 Imperial College London
 University of St Andrews	 UNIVERSITY OF NEWCASTLE UPON TYNE
 CeresPower	 ROLLS ROYCE
 [dstl]	 JM



EPSRC

Engineering and Physical Sciences
Research Council

bbsrc
biotechnology and biological
sciences research council

E·S·R·C
ECONOMIC
& SOCIAL
RESEARCH
COUNCIL

**CARBON
TRUST**

**NATURAL
ENVIRONMENT
RESEARCH COUNCIL**



**UNIVERSITY OF
OXFORD**

**UNIVERSITY OF
SURREY**

**UNIVERSITY OF
GLAMORGAN**

**University
of Glasgow**

**Queen Mary
University of London**

University of East Anglia



Supergen BioFuelCells

Alkaline Exchange PEM fuel cells

Development of thermally
stable OH⁻ conducting
membranes

Development of new
catalysts

Development of fuel cells

- Hydrogen
- Borohydride
- Methanol/ethanol/glycol

Cranfield
UNIVERSITY

Imperial College
London



UNIVERSITY OF
NEWCASTLE UPON TYNE



UNIVERSITY OF
SURREY

[dstl]

CMR
FUELCELL



Acta

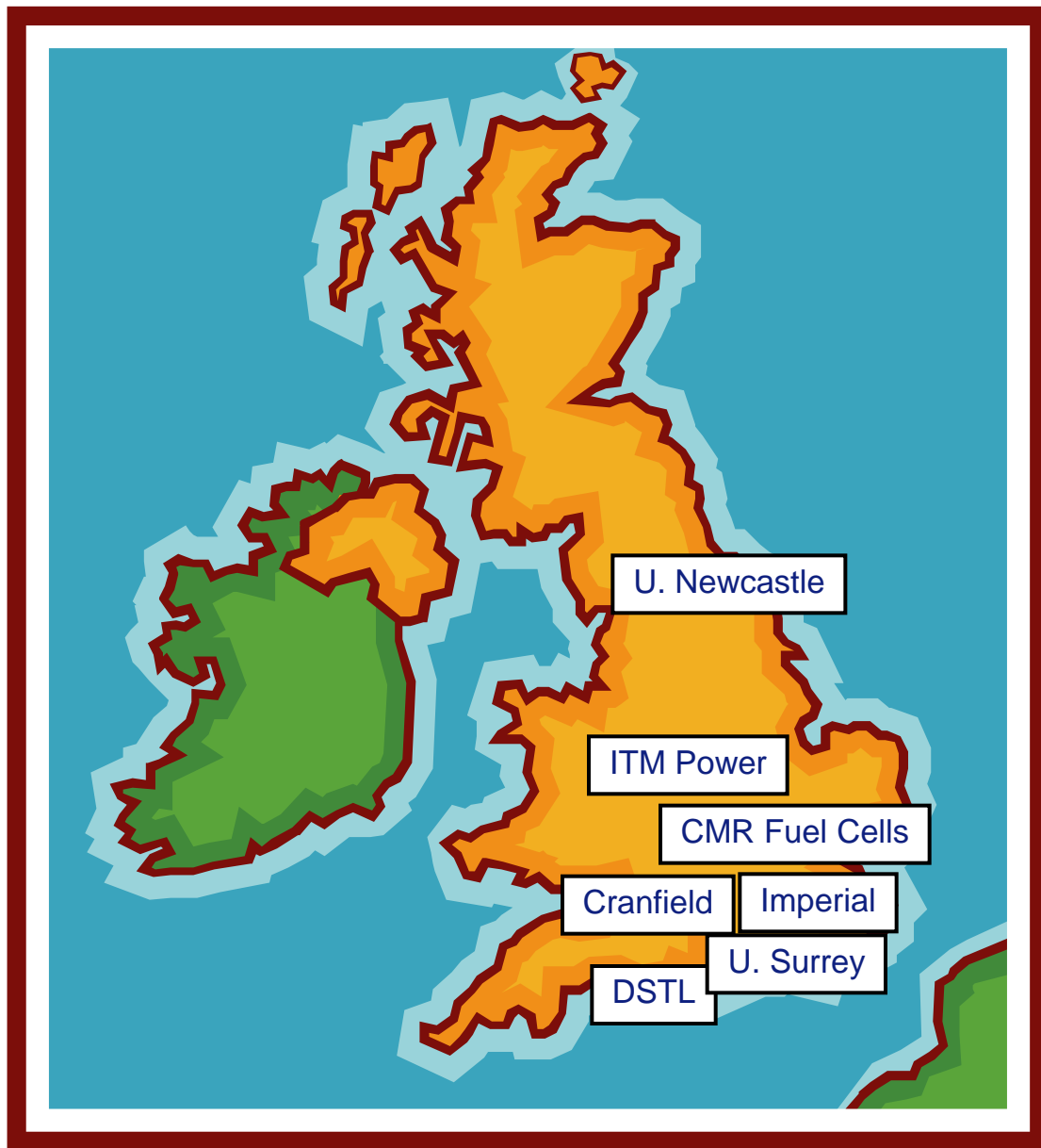

Imperial College, London

- **PEM Research:** Optimisation of catalyst layer in fuel cells through explicit design

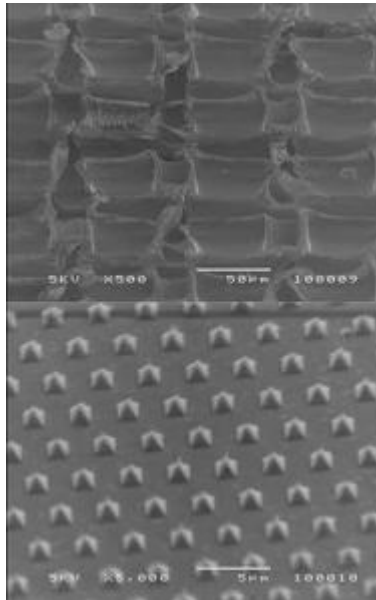

- **SOFC Research:** cathode, anode and electrolyte development. Spin-out: AIM-listed Ceres Power mCHP developer

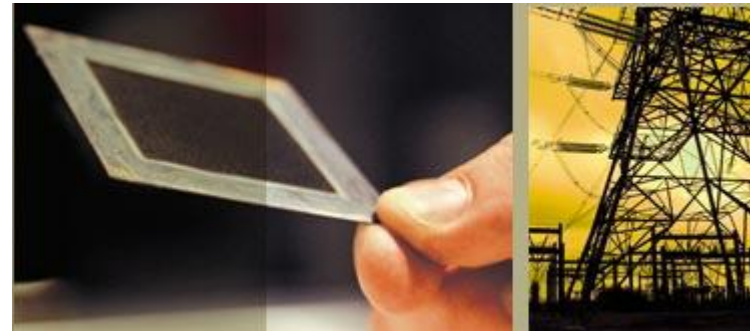



IRG01
48V Architecture
1.2kW PEM Fuel Cell
Lemco LEM200 (2x)
48V x 800A Battery

Hydrogen Storage
5L @ 200bar

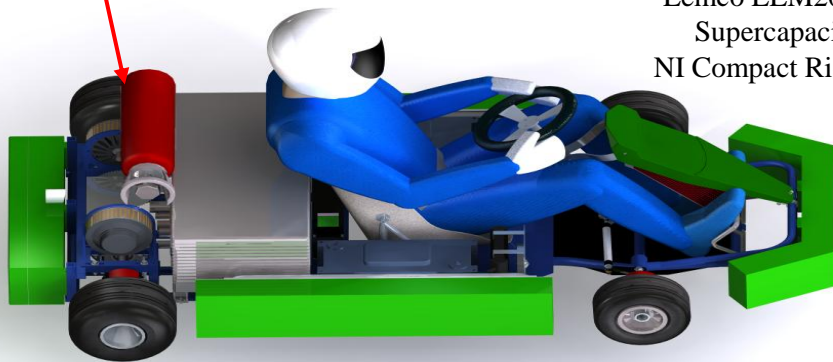

IRG02
48V Architecture
8kW Hydrogenics FC
Lemco LEM200 (2x)
Supercapacitors
NI Compact Rio VMU

Hydrogen Storage
~1.5Kg capacity

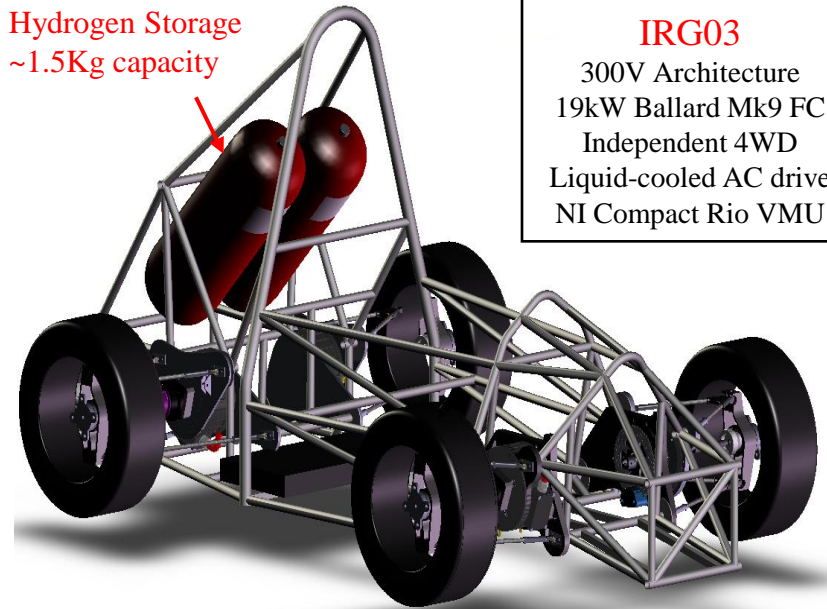

IRG03
300V Architecture
19kW Ballard Mk9 FC
Independent 4WD
Liquid-cooled AC drive
NI Compact Rio VMU



Loughborough University





UNIVERSITY OF
BIRMINGHAM

University of Birmingham

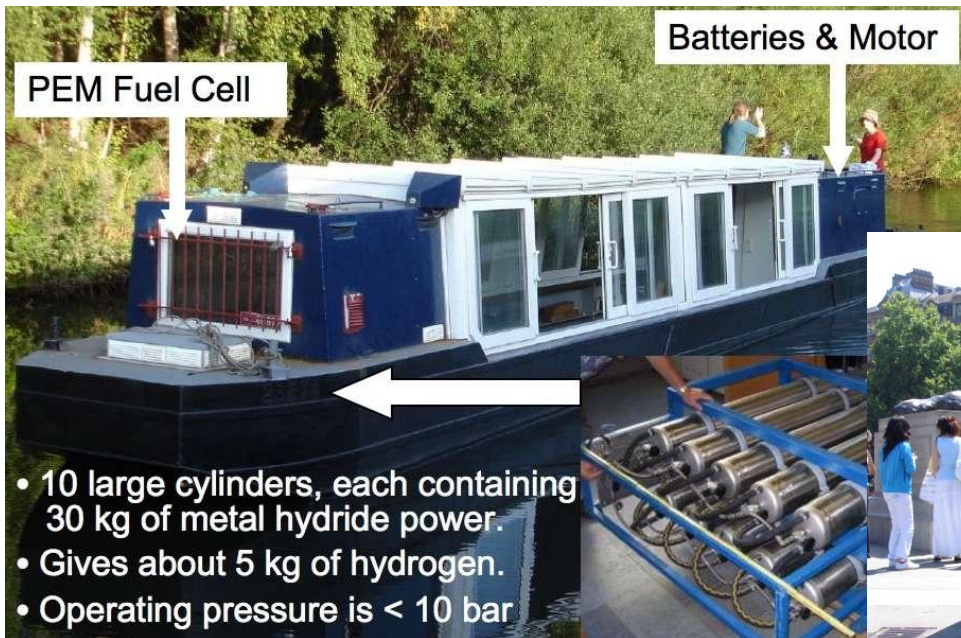

UK companies

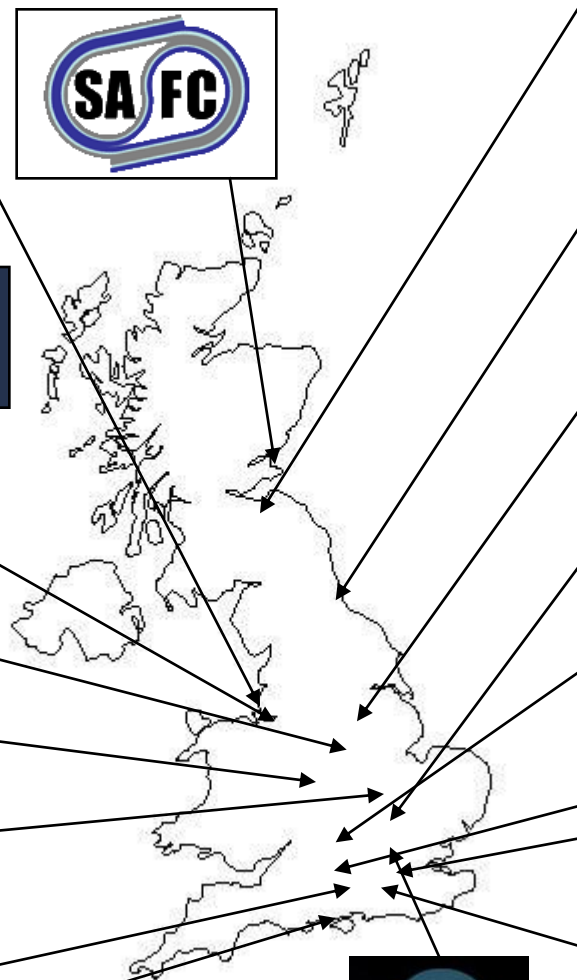
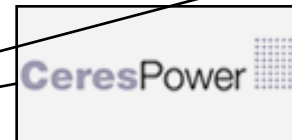
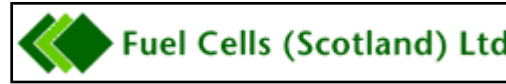
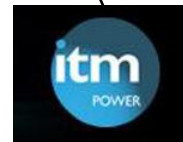

Component manufacturers

NAME	ORIGIN/TECHNOLOGY/ BUSINESS AREA
Bac2 Conductive Composites	Start-up. Bipolar plates using novel materials science.
CMR Fuel Cells	Start-up. DMFC component and stack manufacturer.
Dek Printing Machines	Corporate. Substrates and membrane printing technology.
Johnson Matthey Fuel Cells	Corporate. PEM and PAFC component manufacture.
Oxford Catalysts	University spin-out. Hydrogen-on-demand
Ilika	University spin-out. Materials research.

Stack/system manufacturers

NAME	ORIGIN/TECHNOLOGY/ BUSINESS AREA
Acal Energy	Spin-out. Platinum-free electrode technology.
Adelan	Spin-out. Small-scale tubular SOFC
Ceramic Fuel Cells Limited (CFCL)	Start-up. Residential SOFC CHP developer, tie-in with utilities.
Ceres Power	Spin-out. Residential SOFC CHP developer, tie-in with utilities.
CMR Fuel Cells	Start-up. DMFC component and stack manufacturer.
Intelligent Energy	Spin-out. Stack; system; fuel processing. Product Stack: 1-75kW PEM unit.
Rolls Royce Fuel Cell Systems	Corporate. SOFC manufacturer of 'power plant' (100s kW – MW) scale.
St. Andrew's Fuel Cells.	Spin-out. Tubular SOFC technology.
Voller Energy	Start-up. Portable PEM systems integrator.

System integrators and consultants

NAME	ORIGIN/TECHNOLOGY/ BUSINESS AREA
Element Energy	Engineering consultancy with emphasis on fuel cells
Logan Energy	Systems integrator with experience of installing SOFC and PEM units in buildings
E4Tech	Small consulting company, focusing on cleantech, but with strong track record in hydrogen and fuel cell industry
FCT Consulting	Specialise in fuel cell industry consulting

Adopters/enablers

NAME	TECHNOLOGY/ BUSINESS AREA
CoreTech Ventures	Small VC and advisory company, highly focused on fuel cell techs
Conduit Ventures	Small VC company, focused on wider cleantech industry but with strong emphasis on fuel cells
Black Country Housing Association	Innovative Housing Association with experience of installing and running fuel cells in residential applications and at the University of Birmingham.
LHP/TfL	Transport for London's hydrogen vehicle project will see 60 H2 fuel cell and ICE vehicles on London's roads by 2010.
Pure/Unst	Hydrogen/Fuel cell/Renewable research centre in the Shetlands. Innovative hydrogen community project.
UPS Systems	Fuel cell in UPS Systems office (UPS the fuel cell company, not the delivery company!).
Woking Borough Council	Installed 200 kWe fuel cell on private wires,



- 900deg
- 10 bar
- 55% efficiency

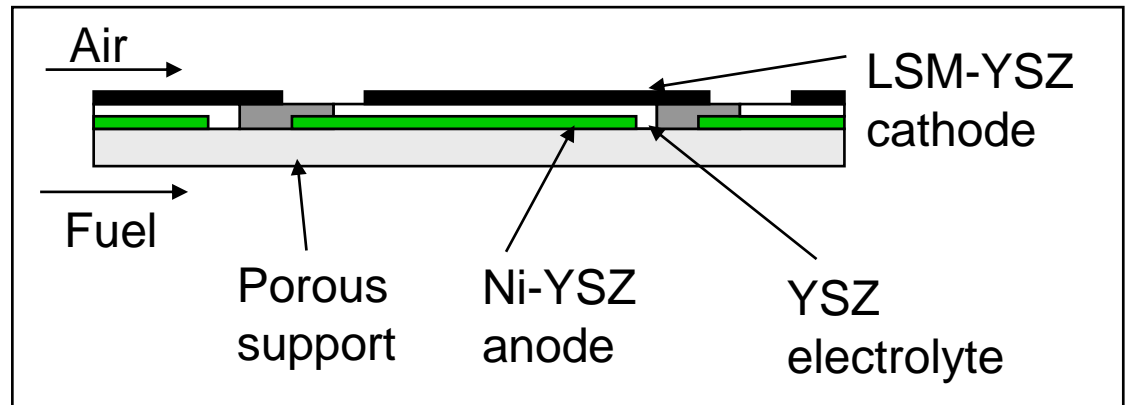

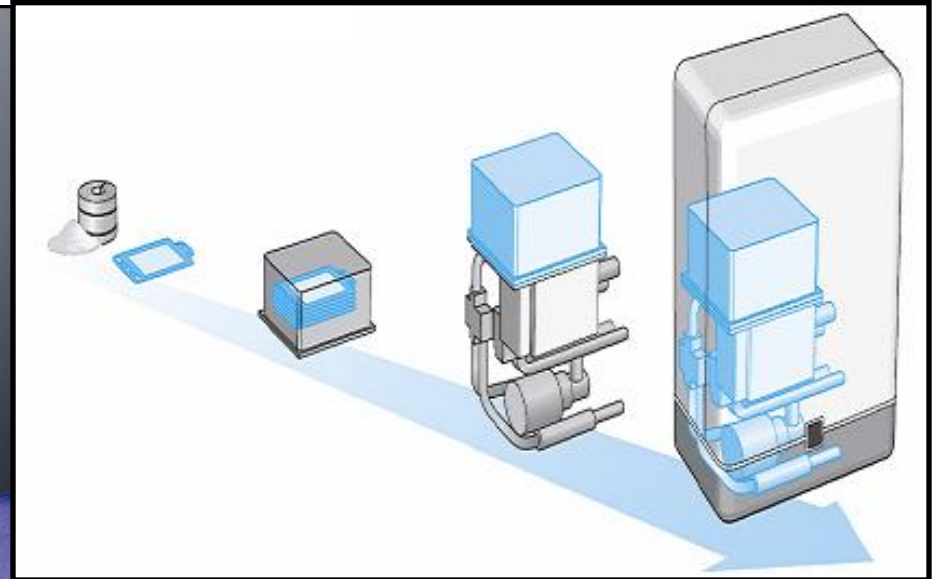

- 1 kW fuel cell stack
- 600deg CGO
- Metal-supported

- Market target:
 - Wall-mounted CHP unit replacing boiler

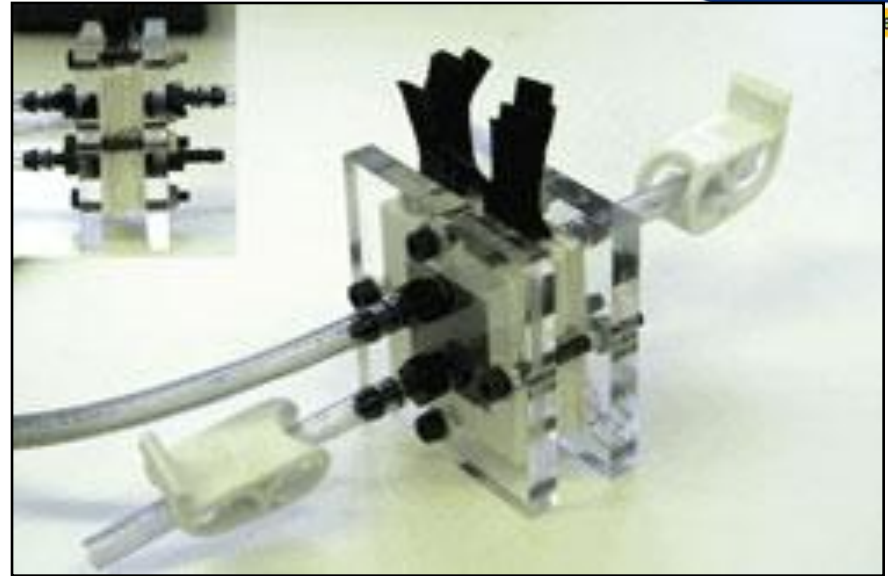
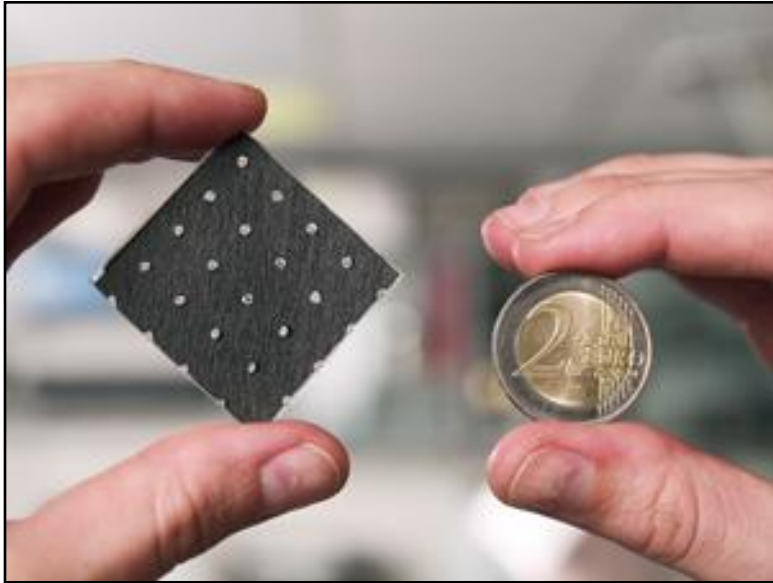

- MicroFC (tens of W)
- Mixed reactants
- Selective catalysts

- Market target:
 - Portable electronics



Boeing plane

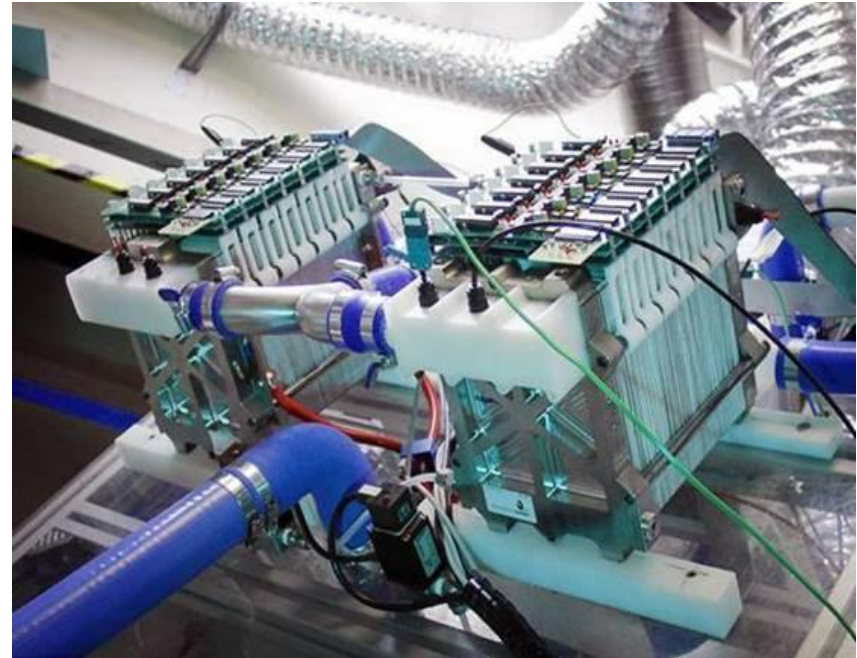

Motorbike - ENV



- High power density metal plate technology
- Automotive and Stationary

www.intelligent-energy.com



- 800deg YSZ
- Multinational company
- Commercial product agreements

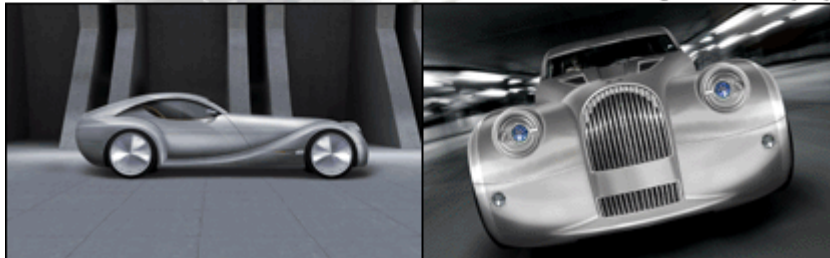
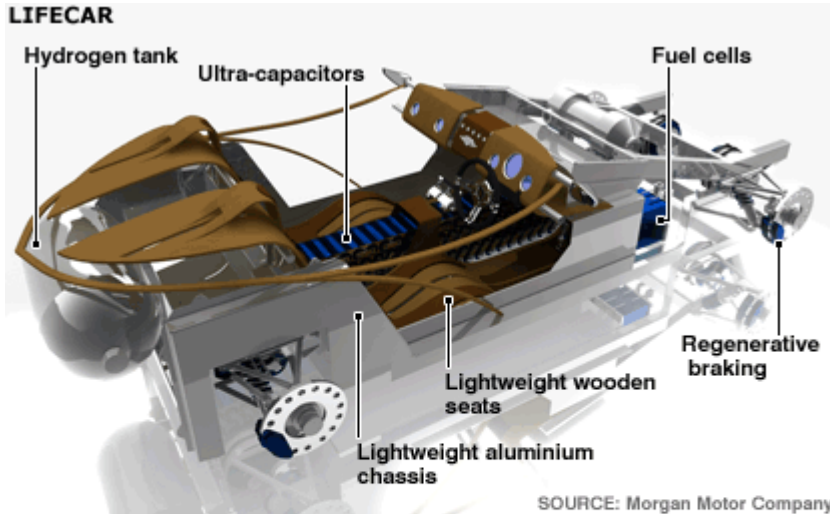

- 10kW PEM
- Morgan vehicle
- Novel structures

Thank You

Kerry-Ann: kerry-annadamson@fuelcelltoday.com

Jonathan: jonathanbutler@fuelcelltoday.com

Ben: bentodd@fuelcelltoday.com